

# Studio System™

## Office-Friendly Metal 3D Printing

Easy-to-adopt Bound Metal  
Deposition 3D printing for any  
office, studio, or lab

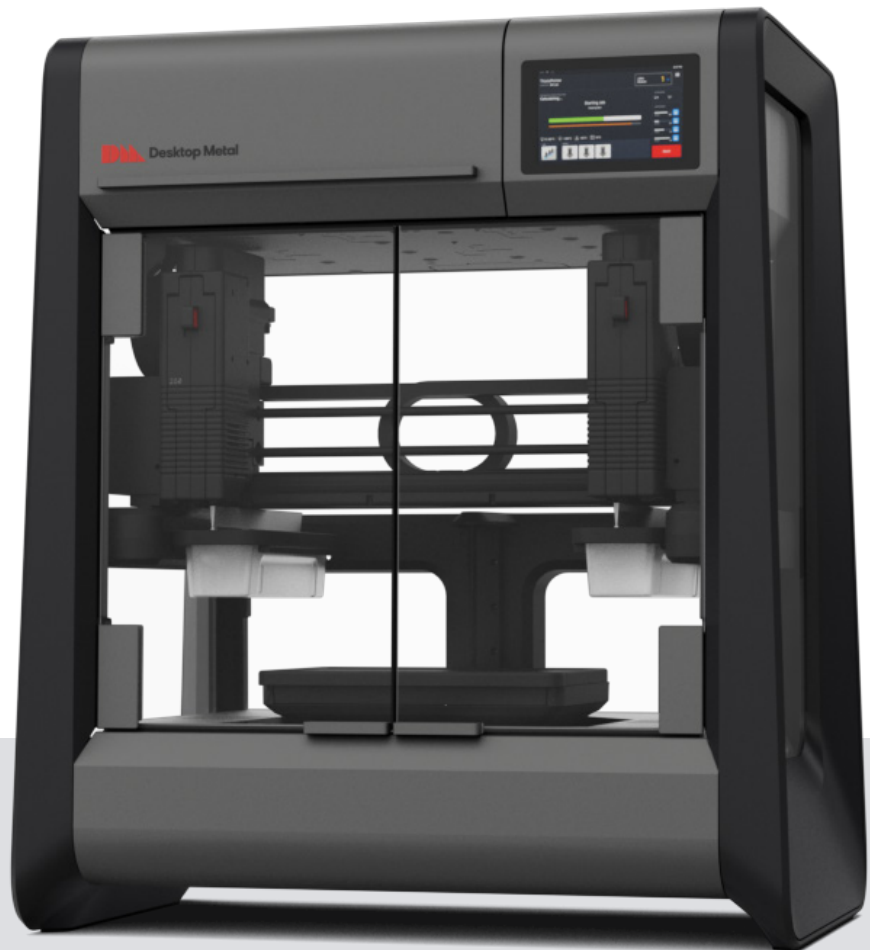



# SIMPLIFIED METAL PART PRODUCTION

Regain ownership of your production pipeline, innovate faster, and manufacture more cost-efficiently with metal 3D printing. The two-step process<sup>1</sup> of the Desktop Metal Studio System™ easily produces difficult-to-machine geometries like undercuts and internal channels while delivering the material properties required for demanding applications. The software at the heart of the Studio System automates complicated metallurgical processes to produce high-quality parts with densities and feature-accuracy similar to casting.

Desktop Metal's print and sinter process, combined with next-generation Separable Supports™ and a software-controlled workflow, makes metal 3D printing simpler than ever. With no solvents, loose metal powder, or lasers, the Studio System is designed for hands-on use with minimal training and runs with little operator intervention. From prototyping to tooling or batch production of end-use parts, the Studio System makes the benefits of metal 3D printing accessible in any office, studio, or lab setting.

## **A complete, turnkey solution**

The Studio System contains all the equipment you need to begin 3D printing metal parts with user-friendly hardware, feedstock, and an intuitive user interface. Designed to be the easiest approach to sintering, the included Desktop Metal Furnace features a large capacity, advanced graphite retort design and low gas consumption for reduced operating costs.

## **Powder-less metal parts**

Safe-to-handle metal rods of pre-bound metal powder and polymer binders, using a formulation similar to the mixture used in Metal Injection Molding (MIM), are available in a variety of alloys. The Studio System is designed for multi-material compatibility and effortless changeovers with easy-to-swap material cartridges that allow for fast changes without cross contamination or powder-handling requirements.

## **Software-controlled process with built-in metallurgy**

Live Studio™ provides an intuitive guide throughout the entire metal 3D printing workflow. From simplified model prep to automated sintering cycles and job queueing, the software applies knowledge from world-leading materials scientists and additive manufacturing experts to automate and optimize the fabrication of high-quality metal parts.

## **Separable Supports**

Our next-generation Separable Supports enable greater design freedom and allow for easy post-processing of complex shapes. Software-generated support structures with strategic seams via a ceramic release layer can be broken away by hand after sintering with no cutting tools required.

Safe, powderless operation with pre-bound metal and binder rods extruded layer-by-layer into complex shapes

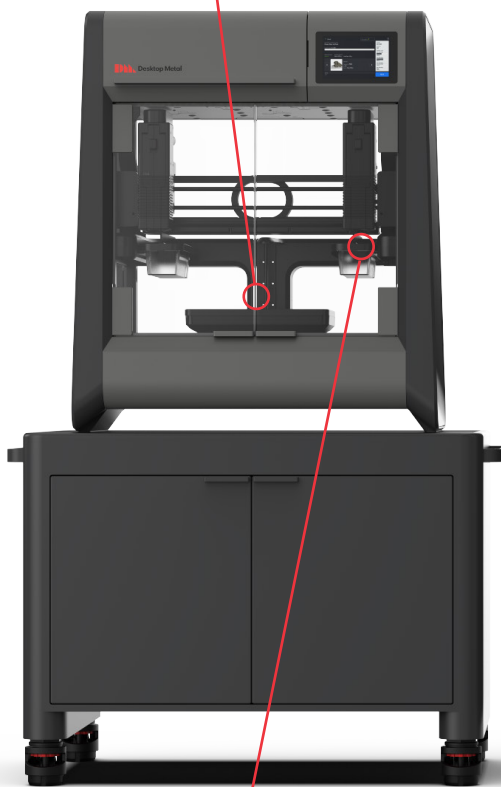
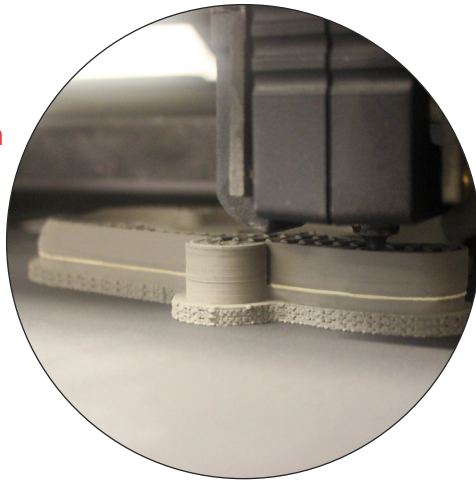

Patented smart Separable Supports via a ceramic release layer for quick post-processing



Industrial-strength sintering in a fully software-controlled and office-friendly package

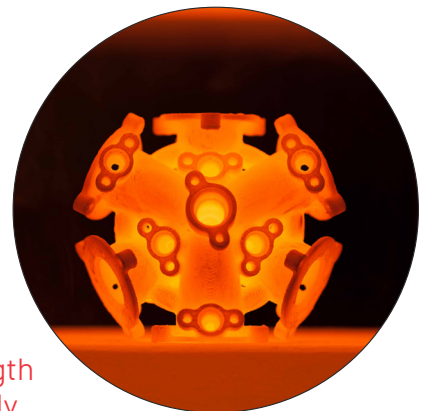



# JUST PRINT AND SINTER

The easy-to-use Studio System leverages proprietary Bound Metal Deposition™ (BMD) technology, a process where pre-bound metal rods are heated and extruded onto a build plate, shaping a part layer-by-layer. The green part is then placed in a furnace, heated to a temperature to remove binder before rising to just below the melting temperature of metal particle fusion, causing the part to densify.

Final material properties surpass MIPF-35 minimum specifications with excellent surface finish and feature resolution while the design freedom of additive manufacturing enables features like fully closed-cell gyroid infill for lightweight strength.

## Nine qualified materials

- 17-4 PH Stainless Steel
- 316L Stainless Steel
- 4140 Low-Alloy Steel
- A2
- Copper\*
- D2 Tool Steel
- H13 Tool Steel
- Nickel Alloy IN625
- Titanium (Ti64)\*

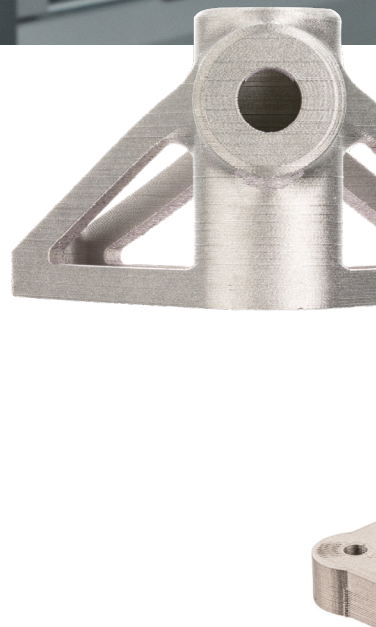
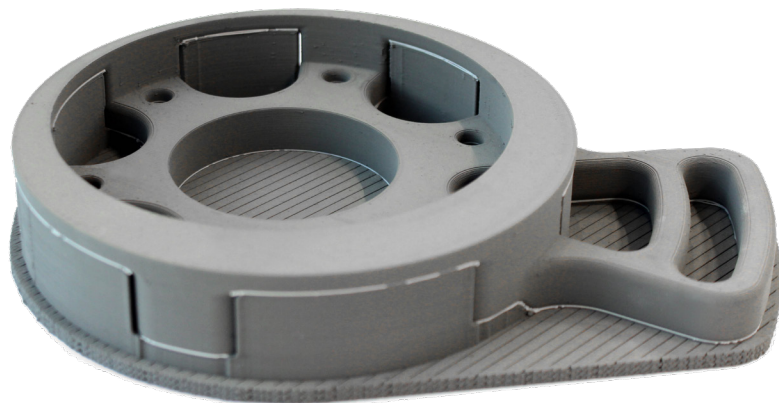



# LIVE STUDIO™ SOFTWARE



Live Studio enables a simple and seamless workflow from digital file to sintered part. It integrates with the Studio System printer and Desktop Metal Furnace to reduce operator burden, ensure process efficiency, and automatically optimize the fabrication of complex, high-quality metal parts without an expert metallurgist or machinist.

Live Studio automates all aspects of part creation, offering step-by-step guidance through the entire workflow from printing through sintering. Live Studio helps users scale parts and orient them for printing and sintering success, generate separable supports, and apply expert metallurgy.

Built-in profiles make build preparation as easy as a few clicks, or adjust any of the print settings traditional plastic extrusion 3D printing users will be familiar with, such as shell layers and infill settings. With dozens of parameters and nearly 100 settings available for adjustment, from printhead resolution to layer heights, the Studio System can fine-tune parts tailored to exacting requirements to meet any manufacturing facility's needs.

## Software controlled process offers easy approach

- Build generation
- Slicing
- Support generation
- Job creation, monitoring, and management



# TECHNICAL SPECIFICATIONS

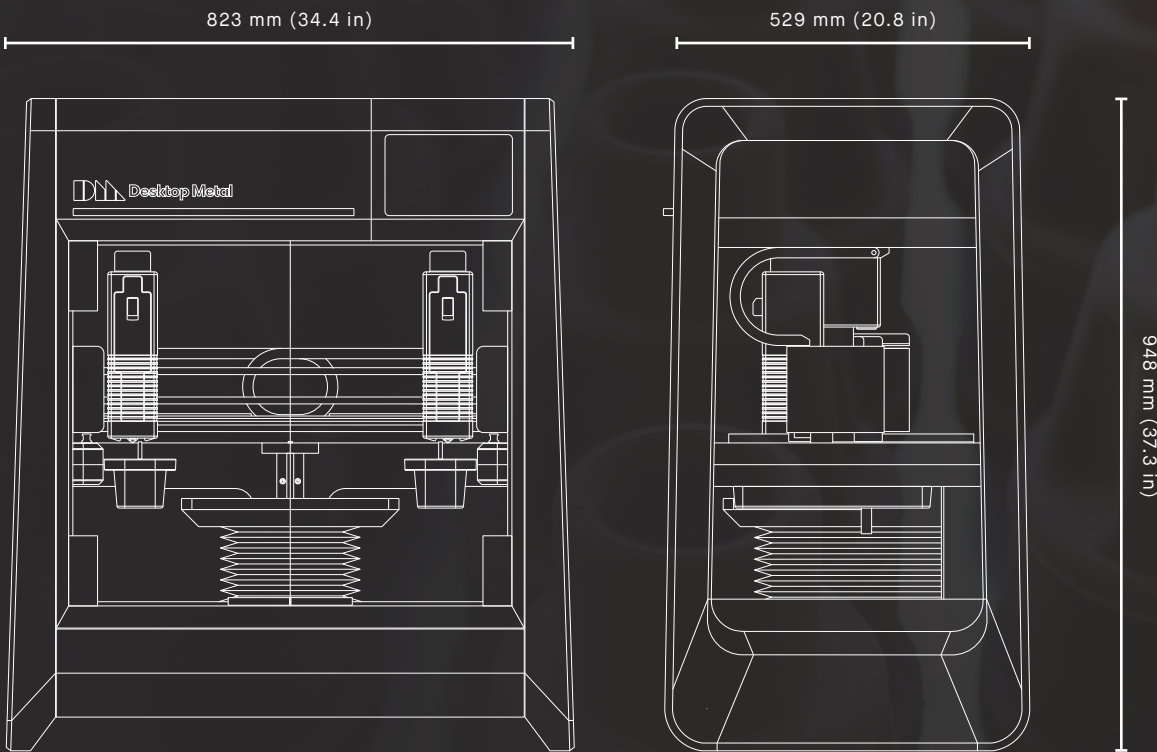

Print technology	Bound Metal Deposition™ with Separable Supports™ via a Ceramic Release Layer™
Feedstock	Bound metal rods (metal powder + polymer binder) in hot-swappable cartridges
Build envelope (L x W x H)	300 x 200 x 200 mm (12 x 8 x 8 in)
Max build weight	6.5 kg (14.3 lbs) in green state
Layer thickness	50 µm - 100 µm, high resolution printhead 150-300 µm, standard resolution printhead
Nozzle diameter	0.25 mm, high resolution printhead 0.40 mm, standard resolution printhead
External dimensions (L x W x H)	94.8 x 82.3 x 52.9 cm (37.3 x 32.4 x 20.8 in)
Weight	97 kg (214 lbs)
Electrical requirements	100-130 VAC, 50/60 Hz, 1-phase 200-240 VAC, 50/60 Hz, 1-phase

*One of the top benefits of the Studio System is the ability to produce the manufacturing devices we need at a lower cost and with greatly reduced lead times. It's opening our minds to completely new design possibilities.*

Alexandre Georgetti  
Senior Manager - Manufacturing Strategy  
Eaton Corporation

# CUSTOMER SUCCESS STORIES



GULLMOLAR

## 100+ Metal 3D Printed Parts on Commercial Fish Processing System

Curio commercial fish processing systems are transformed with over 100 production 316L stainless steel parts 3D printed with bound metal deposition from the Studio System. Office-friendly metal 3D printing is an affordable, easy-to-use solution that reduced time to market by an entire year while increasing yields and freshness of the end-product.

[TeamDM.com/Gullmolar](https://TeamDM.com/Gullmolar)



STATE UNIVERSITY OF NEW YORK NEW PALTZ

## Easy Adoption Success for Students and Business

The Hudson Valley Additive Manufacturing Center at SUNY New Paltz adopted bound metal deposition technology to make metal 3D printing accessible to the local community. The Studio System advances academic opportunities on campus helping students partner with local businesses to innovate and solve real-world production challenges.

[TeamDM.com/HVAMC](https://TeamDM.com/HVAMC)

Learn more about the Studio System and find more customer success stories at

[TeamDM.com/MetalSuccess](https://TeamDM.com/MetalSuccess)

# Additive Manufacturing 2.0

Metal | Polymer | Ceramic | Composite | Wood

Printer platforms



Desktop Health™



Materials



Applications and more



Desktop Labs

[DESKTOPMETAL.COM](https://www.desktopmetal.com)

Desktop Metal (NYSE:DM) is driving Additive Manufacturing 2.0, a new era of on-demand, digital mass production of industrial, medical, and consumer products. Our innovative 3D printers, materials, and software deliver the speed, cost, and part quality required for this transformation. We're the original inventors and world leaders of the 3D printing methods we believe will empower this shift, binder jetting and digital light processing. Today, our systems print metal, polymer, sand and other ceramics, as well as foam and recycled wood. Manufacturers use our technology worldwide to save time and money, reduce waste, increase flexibility, and produce designs that solve the world's toughest problems and enable once-impossible innovations. Learn more about Desktop Metal and our #TeamDM brands at DesktopMetal.com